

# Detail 03: Einspannstütze

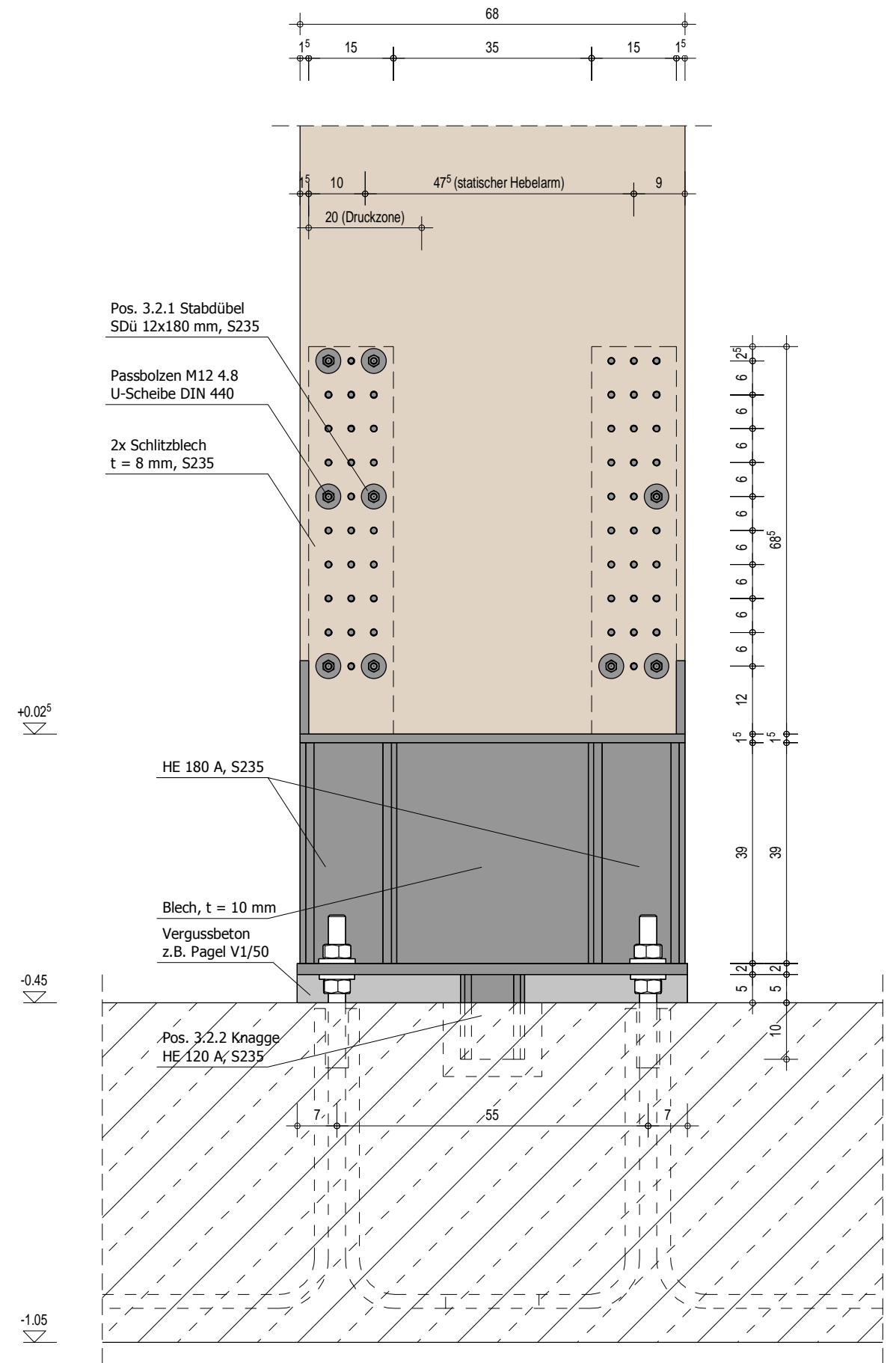
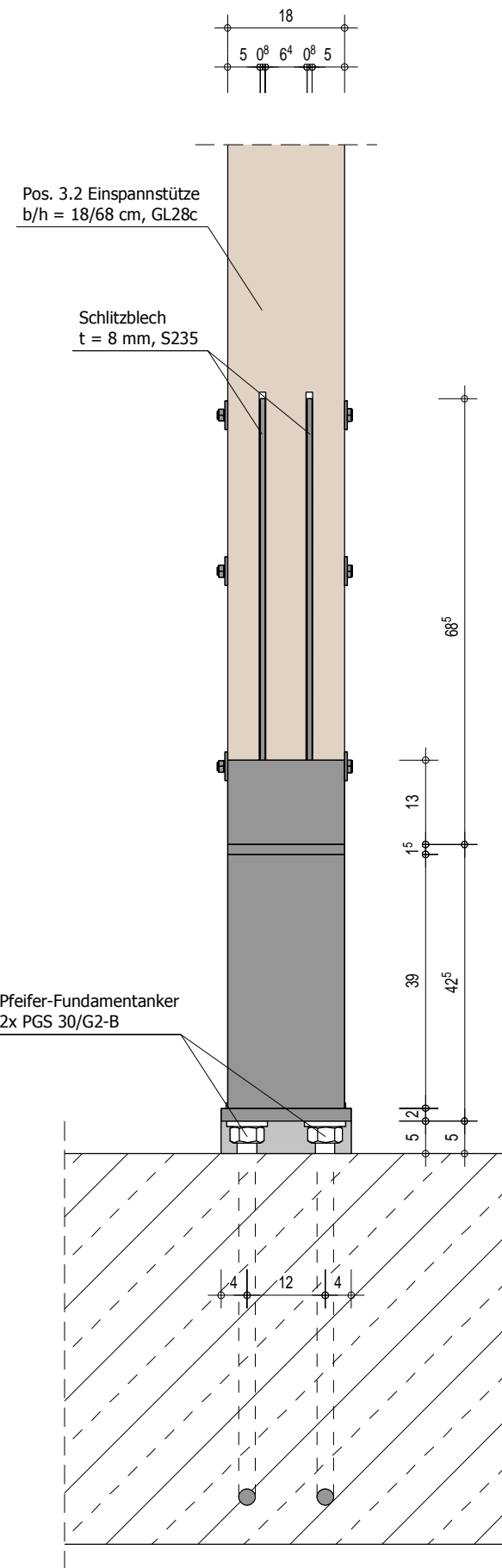
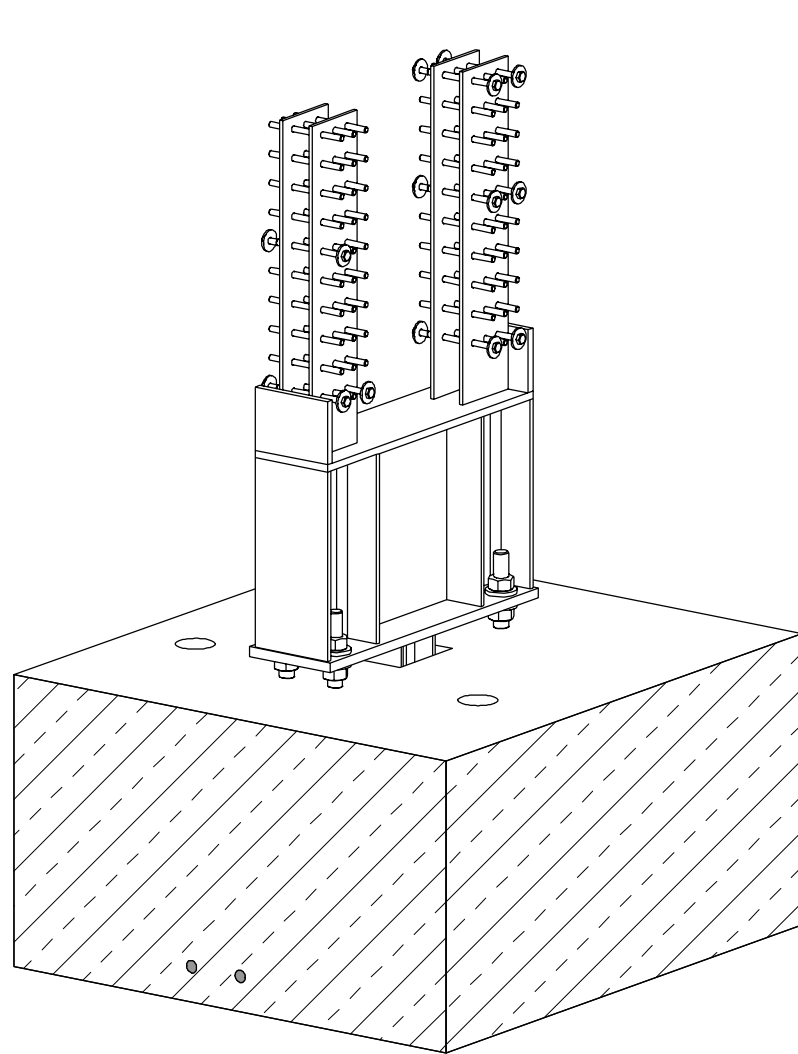

Bauvorhaben 0375-17   Werkhalle mit Büroebene, Meerbusch	Planinhalt Detail 03: Einspannstütze	Maßstab 1 : 10
 ingtools - Bemessungssoftware An der Eickesmühle 26, 41238 Mönchengladbach Tel.: 02166 / 99071-0, E-Mail: info@ing-tools.de, https://www.ing-tools.de		Datum 09.02.2020
		gezeichnet Markus Reimann