

## Verification Dovetail-Connection

according to building approval Z-9.1-649 (validity 18 June 2018 - 5 October 2022)

### Connection & Geometry

one-sided connection

material:	laminated timber
solidity:	GL24c according to DIN EN 14080:2013-09
width secondary beam $b_N$ :	100 mm
height secondary beam $h_N$ :	240 mm
width main beam $b_H$ :	160 mm
height main beam $h_H$ :	280 mm
inclination $\delta$ :	30 °
milling angle $\beta$ :	10 °
pin cone angle $\gamma$ :	4 °
length pin $l_Z$ :	28 mm
width pin $b_Z$ :	90 mm
height pin $h_Z$ :	202 mm
pin hole radius $r$ :	37.3 mm
dimensional tolerances:	+/- 0.2 mm

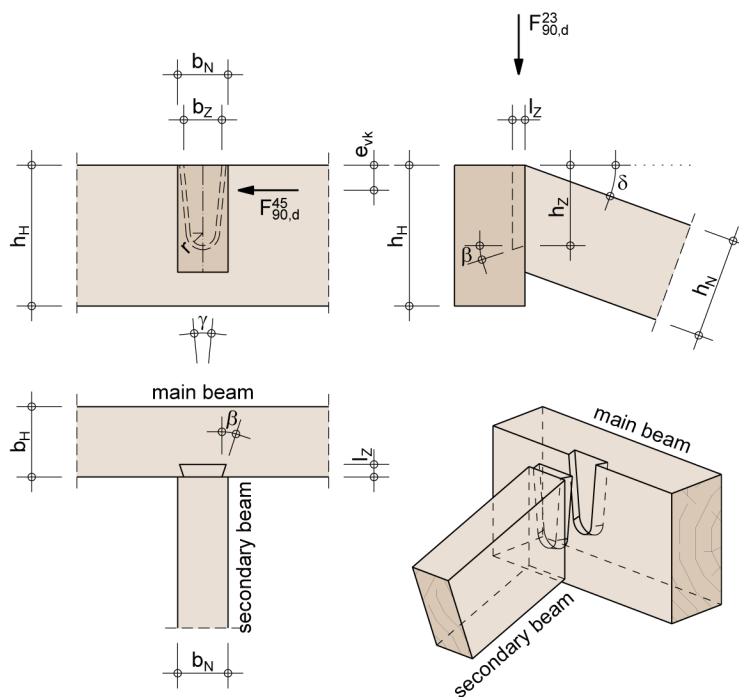

### Loads

Load $F_{23,90,d}$ :	13.00 kN
Load $F_{45,90,d}$ :	0.00 kN
$e_{vk}$ :	0 mm
Service class:	NKL1 - heated interiors
KLED:	medium
modification factor $k_{mod}$ :	0.8

Verification:  $1.00 \leq 1.00$  **Verification fulfilled**  
 Moment  $M_{H,tor,d}$  from one-sided connection 0.858 kNm must be observed with the main beam!

### Construction tip

Building approval Z-9.1-649 must be observed.

**Stress resistance in insertion direction**

$$k_n: \quad 6.50$$

$$\alpha = \cos(\delta) * \frac{h_Z - r}{h_N} = \cos(30) * \frac{202 - 37.3}{240} = 0.59$$

$$k_v = \min \left\{ \begin{array}{l} 1 \\ \frac{k_n}{\sqrt{h_N} * (\sqrt{\alpha} * (1 - \alpha) + 0.4 * \frac{l_Z}{h_N} * \sqrt{\frac{1}{\alpha} - \alpha^2})} \end{array} \right.$$

$$= \min \left\{ \begin{array}{l} 1 \\ \frac{6.50}{\sqrt{240} * (\sqrt{0.59} * (1 - 0.59) + 0.4 * \frac{28}{240} * \sqrt{\frac{1}{0.59} - 0.59^2})} \end{array} \right.$$

$$= \min \left\{ \begin{array}{l} 1 \\ 0.77 \end{array} \right.$$

$$k_{ab}: \quad 1.00$$

$$f_{t,90,d}: \quad 0.308 \text{ N/mm}^2 \quad (\text{with } f_{t,90,k} = 0.5 \text{ N/mm}^2 \text{ according to approval})$$

$$f_{v,d}: \quad 1.538 \text{ N/mm}^2 \quad (\text{with } f_{v,k} = 2.5 \text{ N/mm}^2 \text{ according to approval})$$

$$F_{90,Rd}^{23} = \min \left\{ \begin{array}{l} k_{ab} * \frac{h_Z}{h_Z - r} * \left( 6.5 + \frac{18 * (h_H - h_Z + r)^2}{h_H^2} \right) * (t_{ef} * h_H)^{0.8} * f_{t,90,d} \\ \frac{k_v * b_N * (h_Z - r)}{1.5} * f_{v,d} \end{array} \right.$$

$$= \min \left\{ \begin{array}{l} 1.00 * \frac{202}{202 - 37.3} * \left( 6.5 + \frac{18 * (280 - 202 + 37.3)^2}{280^2} \right) * (100 * 280)^{0.8} * 0.308 \\ \frac{0.77 * 100 * (202 - 37.3)}{1.5} * 1.538 \end{array} \right.$$

$$= \min \left\{ \begin{array}{l} 13.02 \\ 12.98 \end{array} \right.$$

$$\text{stress resistance } F_{90,Rd}^{23}: \quad 12.98 \text{ kN}$$

Verification in insertion direction:	$\frac{F_{90,d}^{23}}{F_{90,Rd}^{23}} = \frac{13.00}{12.98} =$	$1.00 \leq 1.00$
--------------------------------------	--	------------------

### Cross-sectional weakening

width main beam $b_H$ :	160 mm
height main beam $h_H$ :	280 mm
height $a$ :	206.9 mm
length pin $l_Z$ :	28 mm
position of centre $y_0$ :	89.8 mm
position of centre $z_0$ :	145.4 mm
moment of inertia $I_y$ :	26313 cm <sup>4</sup>

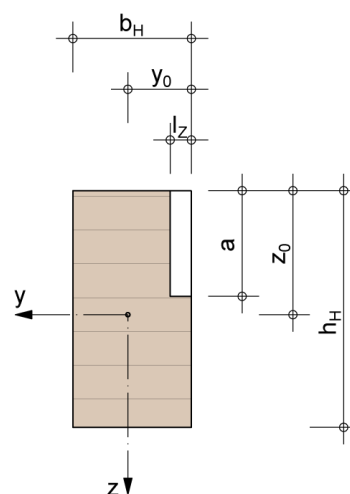

moment of inertia of the unattenuated main beam:

$$I_{y,H} = \frac{b_H * h_H^3}{12} = \frac{160 * 280^3}{12} * 10^{-4} = 29269 \text{ cm}^4$$

required cross-sectional height with the same moment of inertia  $I_y$  related to the unattenuated cross-sectional of the main beam:

width beam $b_H$ :	160 mm
height beam $h_{erf}$ :	290 mm
height $a$ :	206.9 mm
length pin $l_Z$ :	28 mm
position of centre $y_0$ :	89.4 mm
position of centre $z_0$ :	150.9 mm
moment of inertia $I_y$ :	29309 cm <sup>4</sup>

