

Verification Dovetail-Connection

according to building approval Z-9.1-649 (validity 18 June 2018 - 5 October 2022)

Connection & Geometry

one-sided connection

material:	laminated timber
solidity:	GL24c according to DIN EN 14080:2013-09
width secondary beam b_N :	120 mm
height secondary beam h_N :	280 mm
width main beam b_H :	140 mm
height main beam h_H :	440 mm
inclination δ :	20 °
connection angle φ :	60 °
milling angle β :	10 °
pin cone angle γ :	4 °
length pin l_Z :	28 mm
width pin b_Z :	96 mm
height pin h_Z :	254 mm
pin hole radius r :	39.5 mm
dimensional tolerances:	+/- 0.2 mm

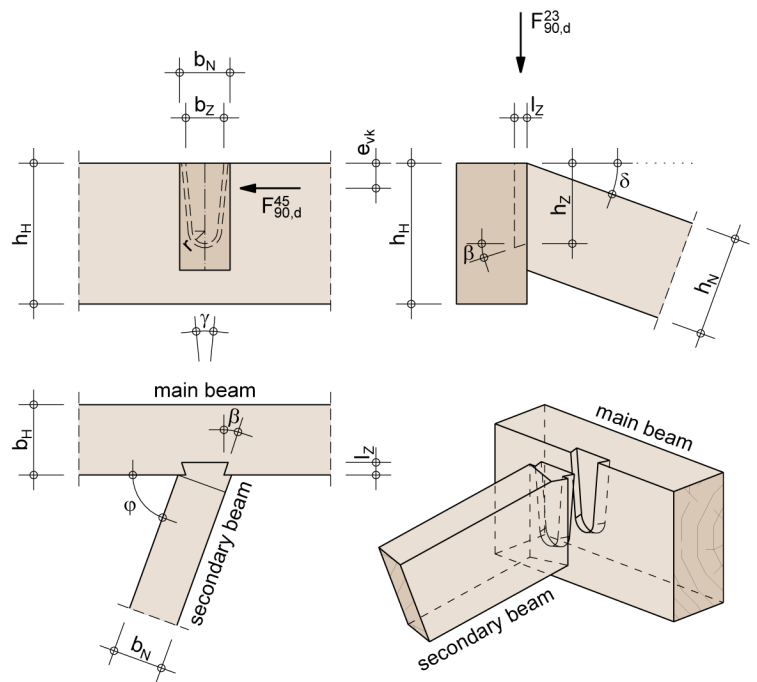

Loads

Load $F_{23,90,d}$:	22.00 kN
Load $F_{45,90,d}$:	4.00 kN
e_{vk} :	0 mm
Service class:	NKL1 - heated interiors
KLED:	short
modification factor k_{mod} :	0.9

Verification:	$0.98 \leq 1.00$	Verification fulfilled
Moment $M_{H,tor,d}$ from one-sided connection 1.232 kNm must be observed with the main beam!		

Construction tip

Building approval Z-9.1-649 must be observed.

Stress resistance in insertion direction

$$k_n: \quad 6.50$$

$$\alpha = \cos(\delta) * \frac{h_Z - r}{h_N} = \cos(20) * \frac{254 - 39.5}{280} = 0.72$$

$$k_v = \min \left\{ \begin{array}{l} 1 \\ \frac{k_n}{\sqrt{h_N} * (\sqrt{\alpha} * (1 - \alpha) + 0.4 * \frac{l_Z}{h_N} * \sqrt{\frac{1}{\alpha} - \alpha^2})} \end{array} \right.$$

$$= \min \left\{ \begin{array}{l} 1 \\ \frac{6.50}{\sqrt{280} * (\sqrt{0.72} * (1 - 0.72) + 0.4 * \frac{28}{280} * \sqrt{\frac{1}{0.72} - 0.72^2})} \end{array} \right.$$

$$= \min \left\{ \begin{array}{l} 1 \\ 0.8 \end{array} \right.$$

$$k_{ab}: \quad 1.00$$

$$f_{t,90,d}: \quad 0.346 \text{ N/mm}^2 \quad (\text{with } f_{t,90,k} = 0.5 \text{ N/mm}^2 \text{ according to approval})$$

$$f_{v,d}: \quad 1.731 \text{ N/mm}^2 \quad (\text{with } f_{v,k} = 2.5 \text{ N/mm}^2 \text{ according to approval})$$

$$F_{90,Rd}^{23} = \min \left\{ \begin{array}{l} k_{ab} * \frac{h_Z}{h_Z - r} * \left(6.5 + \frac{18 * (h_H - h_Z + r)^2}{h_H^2} \right) * (t_{ef} * h_H)^{0.8} * f_{t,90,d} \\ \frac{k_v * b_N * (h_Z - r)}{1.5} * f_{v,d} \end{array} \right.$$

$$= \min \left\{ \begin{array}{l} 1.00 * \frac{254}{254 - 39.5} * \left(6.5 + \frac{18 * (440 - 254 + 39.5)^2}{440^2} \right) * (100 * 440)^{0.8} * 0.346 \\ \frac{0.8 * 120 * (254 - 39.5)}{1.5} * 1.731 \end{array} \right.$$

$$= \min \left\{ \begin{array}{l} 23.86 \\ 23.72 \end{array} \right.$$

$$\text{stress resistance } F_{90,Rd}^{23}: \quad 23.72 \text{ kN}$$

Verification in insertion direction:	$\frac{F_{90,d}^{23}}{F_{90,Rd}^{23}} = \frac{22.00}{23.72} =$	$0.93 \leq 1.00$
--------------------------------------	--	------------------

Stress resistance perpendicular to insertion direction

$$b_{Z,ef} = b_Z - 2 * e_{vk} * \tan\left(\frac{\gamma}{2}\right) = 96 - 2 * 0 * \tan\left(\frac{4}{2}\right) = 96.0 \text{ mm}$$

$$\alpha = 0.5 * \frac{(b_N + b_{Z,ef})}{b_N} = 0.5 * \frac{(120 + 96.0)}{120} = 0.9$$

$$e = \left| \frac{h_Z}{2} - e_{vk} \right| = \left| \frac{254}{2} - 0 \right| = 127.0 \text{ mm}$$

$$k_v = \min \left\{ \begin{array}{l} 1 \\ \frac{k_n}{\sqrt{b_N * (\sqrt{\alpha * (1 - \alpha)} + 0.4 * \frac{l_Z}{b_N} * \sqrt{\frac{1}{\alpha} - \alpha^2})}} \end{array} \right.$$

$$= \min \left\{ \begin{array}{l} 1 \\ \frac{6.50}{\sqrt{120 * (\sqrt{0.9 * (1 - 0.9)} + 0.4 * \frac{28}{120} * \sqrt{\frac{1}{0.9} - 0.9^2})}} \end{array} \right.$$

$$= \min \left\{ \begin{array}{l} 1 \\ 1.69 \end{array} \right.$$

$$F_{90,Rd}^{45} = \frac{k_v * f_{v,d} * h_Z * b_{Z,ef}}{1.5} * \left(\sqrt{\left(\frac{2 * e}{h_Z}\right)^2 + 1} - \frac{2 * e}{h_Z} \right)$$

$$= \frac{1.00 * 1.731 * 254 * 96.0}{1.5} * \left(\sqrt{\left(\frac{2 * 127.0}{254}\right)^2 + 1} - \frac{2 * 127.0}{254} \right)$$

$$= 11.65$$

stress resistance $F_{90,Rd}^{45}$: 11.65 kN

Ver. perpendicular to insertion direction:	$\frac{F_{90,d}^{45}}{F_{90,Rd}^{45}} = \frac{4.00}{11.65} =$	$0.34 \leq 1.00$
--	---	------------------

Compilation of results

Verification in insertion direction:	$\frac{F_{90,d}^{23}}{F_{90,Rd}^{23}} = \frac{22.00}{23.72} =$	$0.93 \leq 1.00$
--------------------------------------	--	------------------

Ver. perpendicular to insertion direction:	$\frac{F_{90,d}^{45}}{F_{90,Rd}^{45}} = \frac{4.00}{11.65} =$	$0.34 \leq 1.00$
--	---	------------------

combined strain:	$\left(\frac{F_{90,d}^{23}}{F_{90,Rd}^{23}}\right)^2 + \left(\frac{F_{90,d}^{45}}{F_{90,Rd}^{45}}\right)^2 =$	$0.98 \leq 1.00$
------------------	---	------------------

Verification:	$0.98 \leq 1.00$	Verification fulfilled
Moment $M_{H,tor,d}$ from one-sided connection 1.232 kNm must be observed with the main beam!		

Cross-sectional weakening

width main beam b_H :	140 mm
height main beam h_H :	440 mm
height a :	258.9 mm
length pin l_Z :	28 mm
position of centre y_0 :	77.5 mm
position of centre z_0 :	232.1 mm
moment of inertia I_y :	88595 cm ⁴

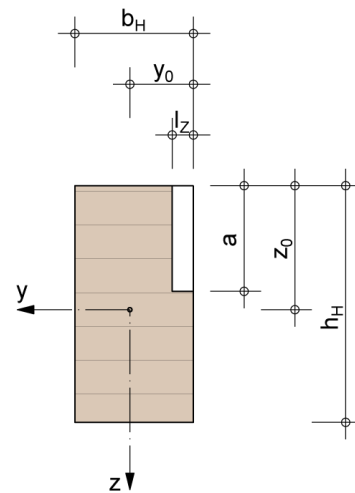

moment of inertia of the unattenuated main beam:

$$I_{y,H} = \frac{b_H * h_H^3}{12} = \frac{140 * 440^3}{12} * 10^{-4} = 99381 \text{ cm}^4$$

required cross-sectional height with the same moment of inertia I_y related to the unattenuated cross-sectional of the main beam:

width beam b_H :	140 mm
height beam h_{erf} :	458 mm
height a :	258.9 mm
length pin l_Z :	28 mm
position of centre y_0 :	77.1 mm
position of centre z_0 :	241.7 mm
moment of inertia I_y :	99935 cm ⁴

